

A global environmental solution company

THE OTTO GROUP

We listen, communicate, respond
& improve...because OTTO cares.



The OTTO Group has been in the business of waste management for well over six decades and over this time, has distinguished herself as being one of the few truly global players, able to provide total and comprehensive waste management solution systems.

Present in all continents, the OTTO Group, together with her affiliates and associates; have been successfully providing waste container storage systems inclusive of up-to-date state-of-the-art waste management equipment to cater for the demands of the environment industry.

Today we remain focused and continue to supply high quality products and services to municipalities as well as to commercial and industrial companies across the Asia Pacific regions. Headquarter in Europe, OTTO has manufacturing facilities in Europe, Eastern Europe, USA and Asia. With her overseas HQ for ASIA in Singapore, she oversees the operations in South-east Asia, Far-east Asia, China, India &, Middle-East continents.

OTTO Group developed a wide range of wheeled containers, product adaptations and unique features, tailored to fulfill the market needs today and in the future. Naturally all our products are tried-and-tested and comply with the highest national and international standards on quality.

OTTO Group offers you a full range of 2 and 4 wheel containers from 60 to 1,100 litres. Our products can be used in combination with all standard collection and lifting technologies, like DIN & AFNOR, but are also suitable to be used in combination with Side Loaders, Front Loaders, Mekam or MSTs systems.

All our waste containers can be tailored to fit recycling schemes, providing specific inserts for paper, glass and various packaging materials. Other available options include a wide range of colours, wheel sizes & qualities, locking systems, trolley systems and solutions to collect different types of waste.

MGB SERIES



WHEELER

Superior material quality and workmanship, low dead weight, user friendly: these are the outstanding features of the wheeled plastic containers made by OTTO.

HDPE

Material high density polyethylene (HDPE)

- Environment-friendly
- Suitable for recycling
- Resistant to chemicals
- Long service life
- Frost resistant
- High resistant to UV radiation



Comb-type Frontal Receiver

- Deeper combs ensure optimum accommodation by the lifting device and facilitate the use of side loaders
- Additional honeycomb/diamond texture for high safety and a long service life
- Eight webs in the chip nest ensure reliable chip positioning
- Comb design according to DIN or AFNOR, DU receiver (Diamond) as an optional extra



Easy Maintenance

- Universal, easily interchangeable parts - requiring fewer spare parts in stock
- Smooth surface in the base area - making for easier cleaning
- Lid less susceptible to wind and rain

EN840

EN840 Certified

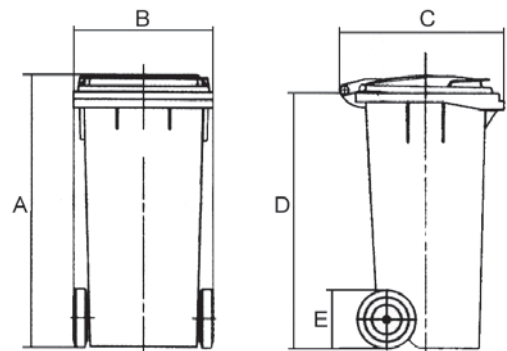

* Containers according to EN840 subject to technical modifications.



MGB 60L

Nom. volume (L)	60
Dead weight approx. (kg)	8.4
Useful load (kg)	40
A - Overall height (mm)	658
B - Overall width (mm)	470
C - Overall depth (mm)	550
D - Upper edge comb (mm)	593
E - Wheel diameter (mm)	200



MGB 80L

Nom. volume (L)	80
Dead weight approx. (kg)	9
Useful load (kg)	45
A - Overall height (mm)	780
B - Overall width (mm)	480
C - Overall depth (mm)	560
D - Upper edge comb (mm)	735
E - Wheel diameter (mm)	200



MGB 120L

Nom. volume (L)	120
Dead weight approx. (kg)	10.5
Useful load (kg)	60
A - Overall height (mm)	940
B - Overall width (mm)	480
C - Overall depth (mm)	550
D - Upper edge comb (mm)	870
E - Wheel diameter (mm)	200



MGB 240L

Nom. volume (L)	240
Dead weight approx. (kg)	14.3
Useful load (kg)	110
A - Overall height (mm)	1080
B - Overall width (mm)	580
C - Overall depth (mm)	730
D - Upper edge comb (mm)	1000
E - Wheel diameter (mm)	200



MGB 360L

Nom. volume (L)	360
Dead weight approx. (kg)	16
Useful load (kg)	160
A - Overall height (mm)	1112
B - Overall width (mm)	585
C - Overall depth (mm)	880
D - Upper edge comb (mm)	1020
E - Wheel diameter (mm)	200



MGB 370L

Nom. volume (L)	370
Dead weight approx. (kg)	19
Useful load (kg)	144
A - Overall height (mm)	1105
B - Overall width (mm)	747
C - Overall depth (mm)	803
D - Upper edge comb (mm)	1032
E - Wheel diameter (mm)	300

A global environmental solution company

MGB SERIES



4

WHEELER

The OTTO MGB 4 WHEELER flat lid and round lid models are dedicated development, integrating numerous improvements to create a smoother design. This means lower operational costs, safer operation and easier handling.

HDPE

Material high density polyethylene (HDPE)

- Environment-friendly
- Suitable for recycling
- Resistant to chemicals
- Long service life
- Frost resistant
- High resistant to UV radiation

DEEP COMB

Comb-type Frontal Receiver

- Deeper combs ensure optimum accommodation by the lifting device and facilitate the use of side loaders
- Additional honeycomb/diamond texture for high safety and a long service life
- Eight webs in the chip nest ensure reliable chip positioning
- Comb design according to DIN or AFNOR, DU receiver (Diamond) as an optional extra

EASY

Easy Maintenance

- Universal, easily interchangeable parts - requiring fewer spare parts in stock
- Smooth surface in the base area - making for easier cleaning
- Lid less susceptible to wind and rain
- Four safe and ergonomic handles
- Improved and repositioned drain plug

EN840

EN840 Certified

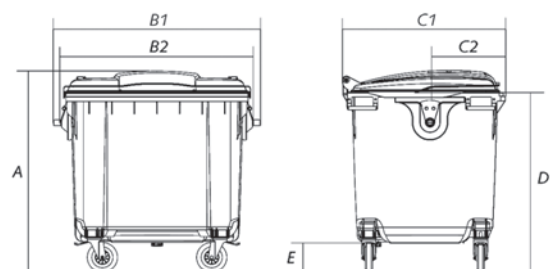

* Containers according to EN840 subject to technical modifications.



MGB 660AL

Nom. volume (L)	660
Dead weight approx. (kg)	41
Useful load (kg)	310
A - Overall height (mm)	1175
B - Overall width (mm)	1260
B1 - Overall width (mm) with trunnions	1310
C - Overall depth (mm)	775
D - Upper edge comb (mm)	1085
E - Wheel diameter (mm)	200



MGB 660SL

Nom. volume (L)	660
Dead weight approx. (kg)	40
Useful load (kg)	310
A - Overall height (mm)	1213
B - Overall width (mm)	1257
B1 - Overall width (mm) with trunnions	1373
C - Overall depth (mm)	780
D - Upper edge comb (mm)	1088
E - Wheel diameter (mm)	200



MGB 660PL

Nom. volume (L)	660
Dead weight approx. (kg)	40
Useful load (kg)	310
A - Overall height (mm)	1219
B - Overall width (mm)	1255
B - Overall width (mm) with trunnions	1355
C - Overall depth (mm)	774
D - Upper edge comb (mm)	1129
E - Wheel diameter (mm)	200



MGB 770L

Nom. volume (L)	770
Dead weight approx. (kg)	43
Useful load (kg)	350
A - Overall height (mm)	1310
B - Overall width (mm)	1260
C - Overall depth (mm)	775
D - Upper edge comb (mm)	1220
E - Wheel diameter (mm)	200



MGB 1100L (FLAT)

Nom. volume (L)	1100
Dead weight approx. (kg)	50
Useful load (kg)	440
A - Overall height (mm)	1354
B - Overall width (mm)	1373
C - Overall depth (mm)	1073
D - Upper edge comb (mm)	1206
E - Wheel diameter (mm)	200



MGB 1100L (ROUND DUAL LID)

Nom. volume (L)	1100
Dead weight approx. (kg)	58
Useful load (kg)	440
A - Overall height (mm)	1455
B - Overall width (mm)	1373
C - Overall depth (mm)	1057
D - Upper edge comb (mm)	1206
E - Wheel diameter (mm)	200

MGB SERIES



Health & Environment authorities worldwide have established strict guidelines in order to ensure accountability and to induce moral obligations of clinical waste producers.

The Biopak-Medical waste containers are made to ensure compliance to such guidelines and implement a duty of care to users for safe disposal of medical waste.

*(Guidelines for Preventing Transmission of Bloodborne Infections in a Healthcare Setting)
From Ministry of Health*

ICG

Infection Control Guidelines

Disposable needles, scalpel blades and other sharp items capable of causing injury must be placed into puncture-resistant containers (e.g. sharp containers) located as close as possible to the area in which they are used. In addition, used needles should never be recapped, purposely bent, broken or otherwise manipulated by hand.

*(Guidelines for Preventing Transmission of Bloodborne Infections in a Healthcare Setting)
From Ministry of Health*



Visibility

Containers should be visible & recognisable to healthcare workers who handle them. The current fill status of the container should be easily observable along with proper warning labels & colour coded, like the BIOPAK series.

Performance criteria of CDC (Centers for Disease Control and Prevention)

Features

- Biopak 6, 10 and 20 have two different needle unwinder slots
- Large label for filling data and information
- Puncture-resistant body, leakage proof
- Autoclavable (Moist Heat 121°C for 45 minutes/134°C for 7 minutes)
- Secure closure lid

BIOPAK	2	6	10	20
Nom. volume (L)	1.63	6	10	20
Dead weight approx. (kg)	0.20	0.45	0.55	0.80
Packaging (per carton)	15 pcs	8 pcs	8 pcs	8 pcs
Carton Dimension (mm)	550 x 360 x 130	540 x 240 x 380	380 x 560 x 270	350 x 340 x 682
Top View (mm)	115	205	240	300
Aperture Size (mm)	80	95	95	95
Front/Side View - A (mm)	85	160	190	230
Top View - B (mm)	130	1205	240	300
Height - C	250	270	285	360



BIOPAK 2
1.63 LITRES



BIOPAK 6
6 LITRES



BIOPAK 10
10 LITRES



BIOPAK 20
20 LITRES

Specifications

- Available in 4 sizes (1.63L, 6L, 10L, 20L)
- Tested according to BS7320:1990
- Designed to meet OSHA standards & CDC guidelines
- Made of Polypropylene
- Suitable for clinics, hospital, research institutions, tattoo shops, veterinary and other healthcare establishments

Assembly ▶ Transport



Instructions for Biopak

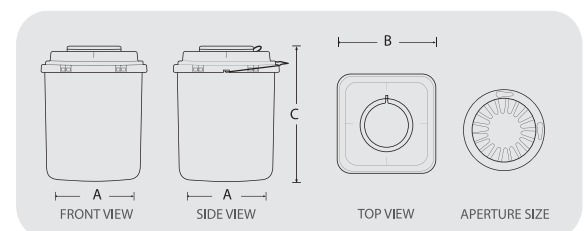



BIOPAK MGB 60
60 LITRES



BIOPAK MGB 120
120 LITRES



BIOPAK MGB 240
240 LITRES



BIOPAK MGB 660
660 LITRES

Features

- Biopak MGB 60, MGB 120, MGB 240 & MGB 660 are 2-wheeled and 4-wheeled waste containers
- Large label for filling data and information
- Secure closure lid with Lid Lock
- Rigid lid prevents spillage during transportation

Specifications

- Available in 4 sizes (60L, 120L, 240L & 660L)
- Yellow in colour
- Designed to meet OSHA standards & CDC guidelines
- Made of Injection Molded High Density Polyethylene (HDPE)
- Suitable for clinics, hospital, research institutions, tattoo shops, veterinary and other healthcare establishments

BIOPAK	MGB 60	MGB 120	MGB 240	MGB 660
Nom. volume (L)	60	120	240	660
Dead weight approx. (kg)	8.4	10.5	14.3	41
Useful load (kg)	40	60	110	310
A - Overall height (mm)	658	940	1080	1175
B - Overall width (mm)	470	480	580	1310
C - Overall depth (mm)	550	550	730	775
D - Upper edge comb (mm)	593	870	1000	1085
E - Wheel diameter (mm)	200	200	200	200
Height - C	250	270	285	360

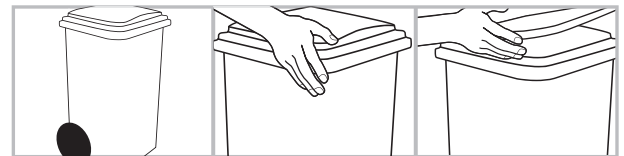

Instructions for Biopak Medical Waste Containers

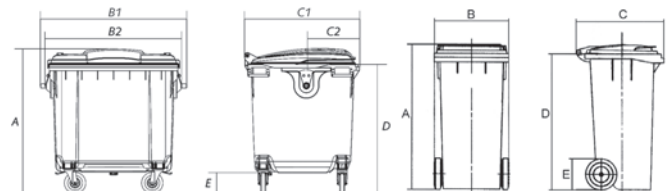

* Containers according to EN840 subject to technical modifications.

Accessories for MGB Biopak Medical Bins

- Biohazard Bag
- Hanger



Cytotoxic Bag



Biohazard Bag



Hanger

MGB OPTIONS



Wheel/Axle

- Solid rubber tyres 200mm/300mm
- Solid material provides high stability (heat-treatable steel)
- Corrosion protected solid steel axle

Handle Bar

- Optimised ergonomic design by larger tube diameter

Smooth Interior

- Ensure optimum emptying and easy cleaning are used. In addition, used needles should never be recapped, purposely bent, broken or otherwise manipulated by hand.

Optional Extra

- Hot stamping
- Embossed text on lid
- Foot pedal (Plastic/steel)
- Recycling lid
- Bio-hazard application & standards for medical industry
- Absorbent resistant

Colours Available

- Standard colours



- Non-Standard colours



- Other colours on request



Deeper combs ensure optimum accommodation on the lifting device

Euro Lid (Lip type handle)

Classical Lid (Bow type handle)

Handle bar, diameter 30mm

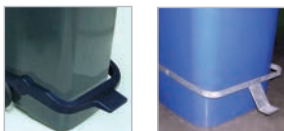

Plastic Foot Pedal Option

Steel Foot Pedal Option



Recycling Turbo Lid Option

Transparent Bin



Stronger In Use

- Stronger, redesigned body
- Reinforced base, wheel housing and comb construction
- Flexible lid to resist maximum strain
- Less wear and tear - increasing expected lifetime
- Improved emptying characteristics due to redesigned and steel reinforced trunnions
- Reinforced and protected hinge arrangement

Ready For The Future

- Ready for use with recycling apertures and various options
- EN 840 certified
- Optimum space for customised markings

Optional Extra

- Hot stamping
- Embossed text on lid
- Foot pedal (Steel)
- Recycling lid
- Bio-hazard application & standards for medical industry
- Absorbent resistant

Colours Available

- Standard colours



- Non-Standard colours



- Other colours on request

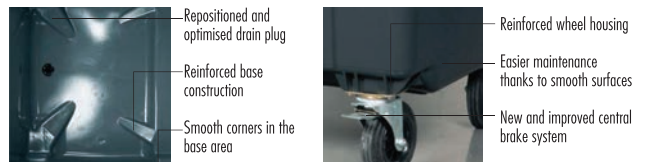

4 Wheel Steel Foot Pedal Option



otto worldwide



OTTO Holding Asia Pacific is a member of the worldwide OTTO Group. The OTTO Group of companies was founded in 1934, and entered the European market in 1950 through mass producing steel litter bins. In 1965, OTTO pioneered the 2-wheel cart with the introduction of plastic manufacturing. The OTTO Group of companies is the largest manufacturer of plastic waste containers in the world. There are over 90 million OTTO containers in use worldwide.





OTTO Waste Systems (S) Pte Ltd

541 Bukit Batok Street 23
#03-00 Tacam Industrial Building
Singapore 659546
Tel: (65) 6898 1267
Fax: (65) 6268 5193
Email: sales@ottoasiapac.com

www.ottoasiapac.com

All models and equipment versions specifications listed are subject to change without prior notice.
Otto reserves the right to make necessary alterations in details for final production of models and equipments.
Deviations from colours and shape shown in illustrations may occur.
No part is to be reproduced without the written approval of Otto Waste Systems (S).